



# Change'Air™

PRODUCTS AND SERVICES LTD.

## Engineered Excellence for Greener Classrooms

### Vertical Classroom Air Handler

The Change'Air standard "Air Handler" ranges from simple to complex depending on your application and the options you require. This typical chilled water/hot water or electric design can have options like factory installed valve packages, built in power relief, a gas furnace or many other standard upgrades. This series has our most versatile cabinet options to fit the most demanding applications. This classroom air handler is a popular choice for areas with high capacity demands to restricted space requirements.

- ✓ Standard hot water/chilled water
- ✓ 2 pipe or 4 pipe configurations
- ✓ Optional Electric or Gas
- ✓ Optional internal power relief fan
- ✓ Full economizer capability
- ✓ Split system cooling coils
- ✓ Various supply fan options
- ✓ Factory installed piping packages
- ✓ Optional internal power relief fan
- ✓ LonMark or BACnet Controllers

## Freshman Series

Option	Details						
Cabinet Sizes	"A" (91"h x 36.5"w x 18"d)		"B" (91"h x 39.75"w x 25"d)		"C" (91"h x 46.75"w x 25"d)		
Design Options	Standard Heating/Cooling Design				Face & Bypass Damper Design		
Heating	Hot water Coil 1 or 2 row up to 111 MBTU		Steam Coil 1 or 2 row up to 145 MBTU		Electric Resistance Up to 15 KW		Gas Furnace Modulating up to 90 MBTU
Cooling	Free Cooling Economizer Damper	Chilled Water Coil 3, 4 or 5 row up to 72 MBTU			Split System Evaporator/Heat Pump Coil 3 or 4 row up to 84 MBTU		
Cooling Options	Stainless Steel Drain Pan	Insulated Drain Pan		Valve Packages for Chilled Water (Factory Installed)			
Ventilation	Standard Damper Assembly (Outside/Return Air Damper)						
Supply Fan Motor	LC-S ½ hp 1 fan body (1050 cfm max.)	LC-D ½ hp 2 fan bodies (1100 cfm max.)	SC-S ½ hp 1 fan body (1300 cfm max.)	SC-D ½ hp 2 fan bodies (1400 cfm max.)	HC-S ¾ hp 1 fan body (1600 cfm max.)	HC-D ¾ hp 2 fan bodies (1800 cfm max.)	XHC-D 1 hp 2 fan bodies (1800 cfm max.)
Power Relief	XLC-ERM ½ hp (550 cfm max.)		LC-ECM ½ hp (1000 cfm max.)		SC-ECM ½ hp (1200 cfm max.)		HC-ECM ½ hp (1600 cfm max.)
Fan Speed Control	ECM (3 speed 24 VAC or 0-10 VDC signal)				ERM (single or dual fully adjustable speed board)		
Electrical Supply	"A" 115/1/60	"B" 208/3/60		"C" 208-230/1/60		"D" 277/1/60	"E" 460/3/60
Controls	CACS Stand Alone Programmable ES Stat	Factory Preprogrammed LonMark Compatible Controller		Factory Preprogrammed BACnet Compatible Controller		Supplied by Other Factory Installed	
Insulation	Standard Fibreglass Ductliner (airside coated)			Closed Cell		Perforated Steel Liner	
Filters	1" Pleated Disposable		2" Pleated Disposable		Permanent Washable		Media Filter Rack with Replaceable Media
	MERV 8 (Standard)			MERV 11		MERV 13	

**Important Note:** This is not a compatibility table. Each option shows the available for the Series or model. For compatibilities on a specific design configuration please call your Change'Air sales representative.

:Shaded areas show options available but not reflected in the drawings on reverse side.

# FRESHMAN HCW 36 1000 B C

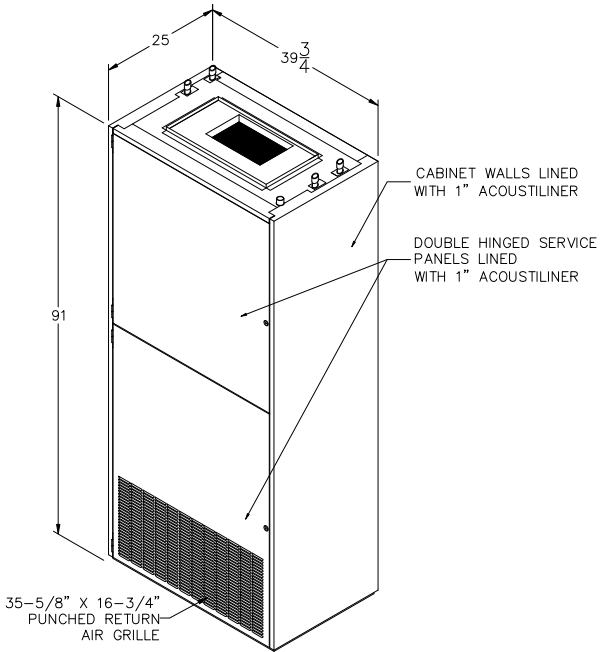

ISOMETRIC VIEW

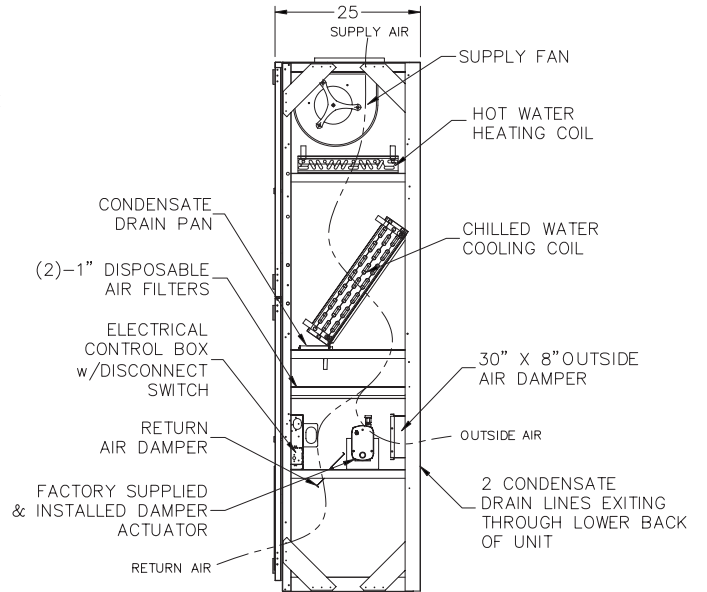

RIGHT SIDE VIEW

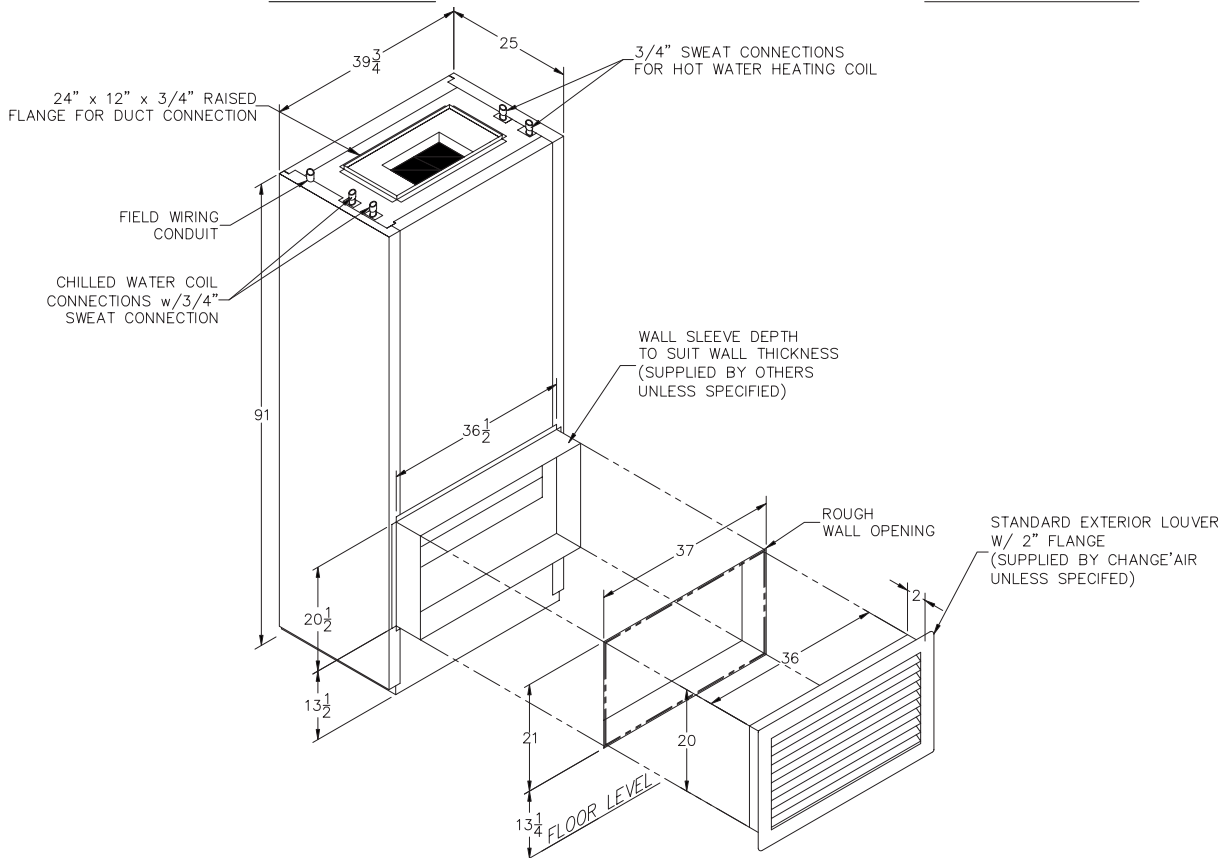

INSTALLATION VIEW