

Pipe Chase

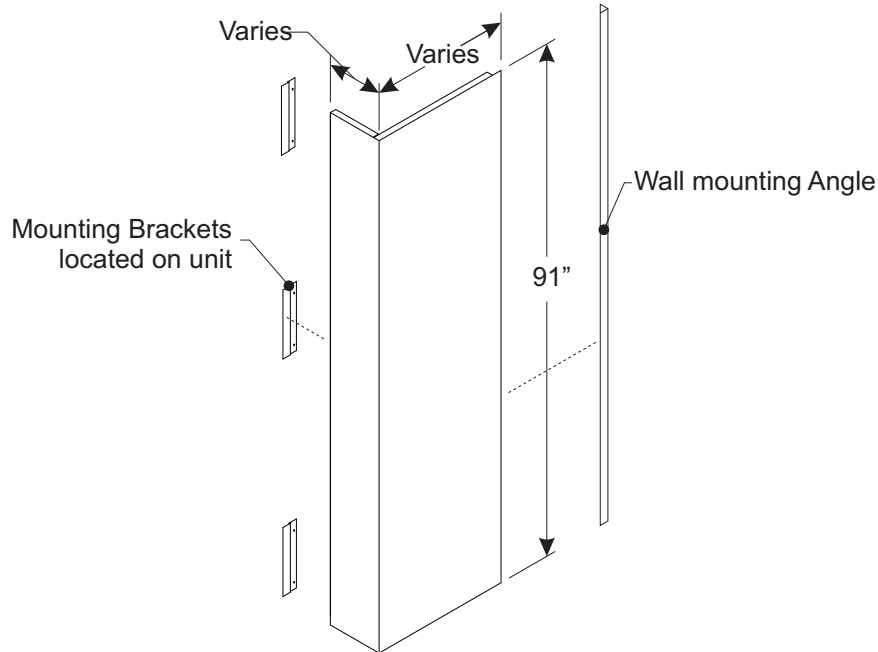

Standard Features:	Options:
Height will match unit (91")	Width/depth can be adjusted to suit site conditions
Finish will be the same as the unit	
Supplied uninsulated	For sound deadening: <ul style="list-style-type: none"> • 1" closed cell insulation • 1" fiberglass insulation with a black mat on the air side
Wall mounting angle (unpainted) Supplied (90°h)	Can be painted to match
Mounting Brackets installed on unit (unpainted)	Can be supplied loose for field installation
Can be mounted either left or right side of the unit	

Design Consideration:

The pipe chase is removable. An access panel or door can be added for access to control valves. A pipe chase extension can be supplied if an uninsulated duct cover or an insulated top plenum is supplied. Ensure there are no obstructions that will interfere with the placement of the accessory. Special consideration should be given to site conditions.